

**SET SENZOR DE PARCARE CU
AFIŞAJ LED FĂRĂ FIR**

Model SP 003

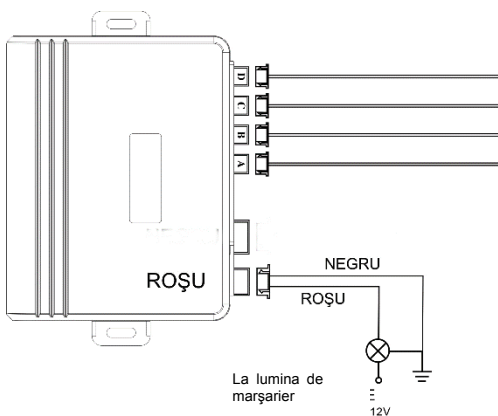

La lumina de
mașarier

12V

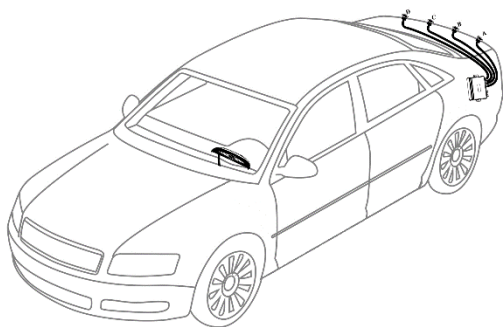

NOTĂ

1. Sistemul va fi instalat pe vehicule cu tensiunea de 12V, minus la masă
2. Se recomandă ca instalarea să fie executată de un specialist
3. Acordați atenție cablajului, evitați zonele cu temperaturi și tensiuni ridicate
4. Conductorii vor fi izolați cu bandă izolatoare autoadezivă
5. La terminarea instalării se recomandă testarea sistemului

Funcții și utilizare

Sistemul este destinat pt. a avertiza conducătorul despre obstacolele aflate în spatele vehiculului în cazul mersului în marșarier.

Sistemul se compune dintr-un modul central, senzori ultrasonici, afișaj cu LED.

Sistemul ajută la evitarea obstacolelor cauzate de obstacole chiar și invizibile din poziția conducătorului. Sistemul este sigur, simplu și fiabil, păstrându-și calitățile excepționale timp îndelungat.

Caracteristici

1. Sistemul devine activ în cazul mersului în marșarier.
2. Raza de acțiune lungă, până la 2 m în spatele vehiculului
3. Semnal LED la mersul în marșarier
4. Toți senzorii sunt supuși la teste de duranță pt. fiabilitate maximă
5. Funcționare excelentă și în condiții meteo grele, protecție împotriva perturbațiilor electromagnetice

Date tehnice:

1. Tensiunea de alimentare: 10,8V...15V
2. Curent absorbit: 120 mA
3. Putere maximă: 2W
4. Temperatura de lucru: -40 °C ... +80 °C
5. Raza de detectare: 1,5m...0m

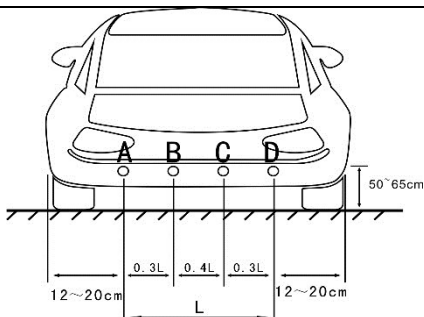

Înălțimea de la centrul senzorului până la sol este de 50...65 cm.
Înălțimea ideală este 55 cm.

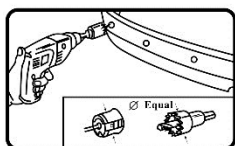

ALEGEȚI BURGHIU
POTRIVIT

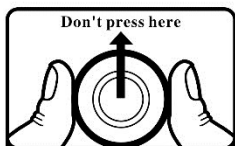

NU APĂSAȚI CENTRUL
SENZORULUI

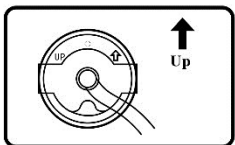

RESPECTAȚI POZIȚIA
DE INSTALARE

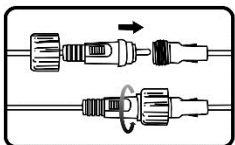

FIXAȚI CORECT CAPIȘONUL
ERMETIC

SITUAȚII ÎN CARE SENZORUL NU FUNCȚIONEAZĂ

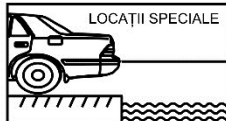
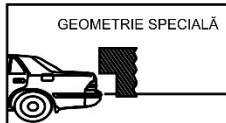
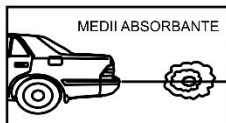
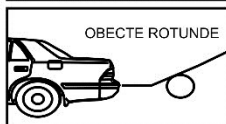
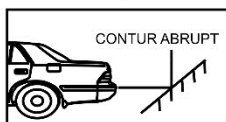

- După instalarea conducătorul trebuie să se convingă de buna funcționare a sistemului
- Furtuna, sau paraziiții electromagnetici pot influența eficacitatea detectării
- Deoarece acesta este un sistem de atenționare auxiliar, fabricantul și distribuitorul nu își asumă nici o răspundere la provocarea vreunor accidente.

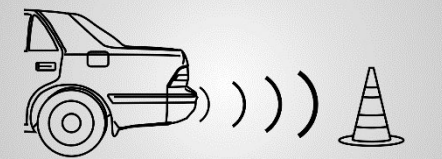

**LED KIJELZÉSŰ, VEZETÉK
NÉLKÜLI
TOLATÓRADAR**

Típus SP 003

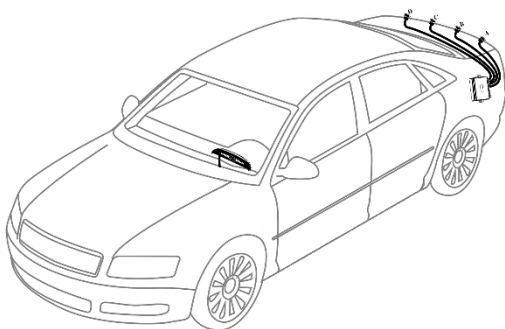
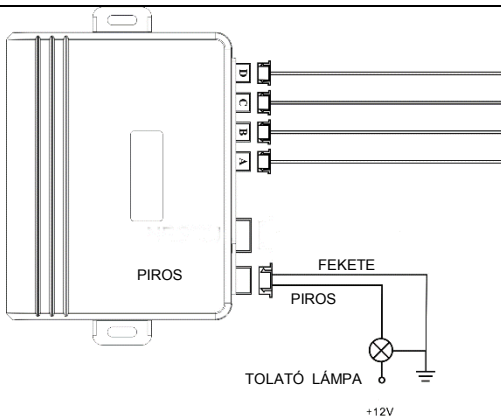

MEGJEGYZÉS

6. A rendszer 12 V-os és negatív testelésű gépkocsira szerelhető
7. A rendszer beszerelését ajánlatos szakemberre bízni
8. A kábelezést figyelmesen végezzék el, kerüljék a magas hőmérsékletű és feszültségű területeket
9. A kábelkorbácsot műanyag szigetelőszalaggal fogják össze
10. A rendszer beszerelése után ellenőrizze a helyes működést

Szolgáltatások és használatuk

A rendszer célja tolatásban haladáskor tájékoztatni a vezetőt a gépkocsi háta mögött elhelyezkedő akadályokról

A rendszer egy központi egységből, az érzékelőkből és a LED-kijelzőből áll.

A rendszer biztonságos, egyszerű, és megbízható működésű

Jellemzők

1. A rendszer hátramenetben (tolatásban) válik aktívvá
2. Nagy hatótáv, 2 m a jármű háta mögött
3. Hangjelzés hátramenetben
4. Minden érzékelő tartós-tesztnek lett kitéve a megbízhatóság érdekében
5. Stabil működés nehéz időjárási viszonyok, illetve elektromágnesesen zavart környezetben is.

Műszaki adatok

1. Tápfeszültség: 10,8V...15V
2. Felvett áram: 120 mA
3. Maximális teljesítmény: 2W
4. Üzemi hőmérséklet: -40 °C ... +80 °C
5. Érzékelési távolság: 1,5m...0m

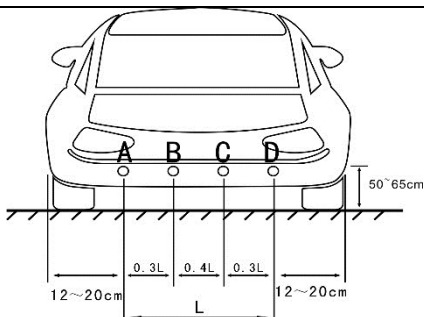

A szenzorok közepétől magasság a talajtól mérve 50...65 cm
Ideális magasság: 55 cm

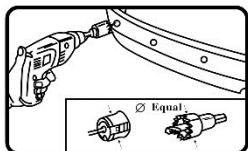

HASZNÁLJON MEGFELELŐ
FÚRÓT

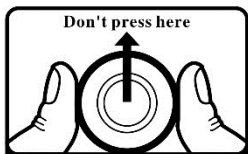

NE NYOMJA MEG AZ
ÉRZÉKELŐ KÖZEPÉT

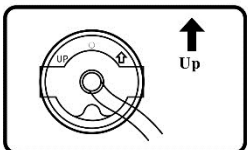

TARTSA BE A BESZERELÉSI
IRÁNYT

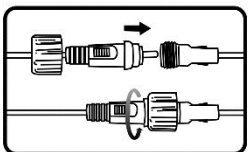

RÖGZÍTSE A VÍZÁLLÓ
VÉDŐSPKÁT

EZEKBE A HELYZETEKBE A RENDSZER NEM MŰKÖDIK

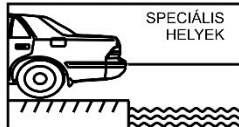
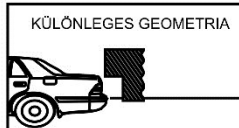
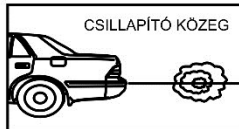
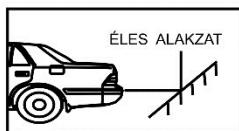

- Beszerelés után, a vezető győződjön meg a helyes működésről
- A vihar vagy az elektromágneses zavarok befolyásolhatják az érzékelést
- Mivel ez egy tájékoztató figyelmeztető rendszer, a gyártó és forgalmazó semmilyen felelősséget nem vállal az esetleges balesetekkel kapcsolatban.